



FAMU-FSU  
College of  
Engineering

# JTEKT Bearing Painter VDR 2

Senior Design Team 515





# Team Introductions



Mason Gibson  
*Manufacturing  
Engineer*



Wesley Jean-Pierre  
*Mechanical Design  
Engineer*



Max Jones  
*Project Manager &  
Control Engineer*



Andrew McClung  
*Systems Integration  
Engineer*



Anthony Wuerth  
*Manufacturing &  
Design Engineer*



# Sponsor and Advisor



Engineering Mentor  
Joshua Jones  
*Process Engineer*  
*JTEKT North America*



Academic Advisor  
Shayne McConomy, Ph.D.  
*Senior Design Professor*



# Project Objective

The objective of this project is to automate the process of painting needle bearing retainers.

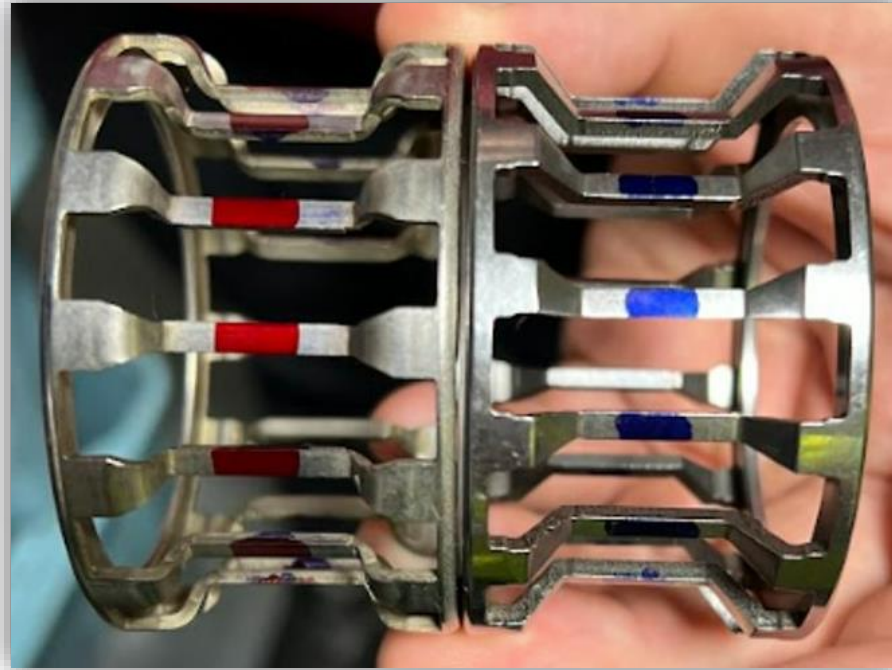

# Project Overview

Wesley Jean-Pierre



# Key Goals



Accurately Apply  
Metal Paint to  
the Bearing



Accommodate  
Bearings from  
7/8-2 ½ in.  
(Outer Diameter)



Automate Bearing  
Painting Process

# Assumptions



Manually Loaded and Unloaded



Loaded with One Type of Bearing at a Time



A standard 120V Wall Outlet is Available



Paint With One Color per Load

# Customer Needs



Fully Automated  
(except loading)



Fit Into Existing Fume Hood



Accommodate Different  
Sized Bearings



Able to Load 10 Bearings  
at a Time



3.5 Second Cycle Time



Paint Non-Working Surface Only



# Defined Systems

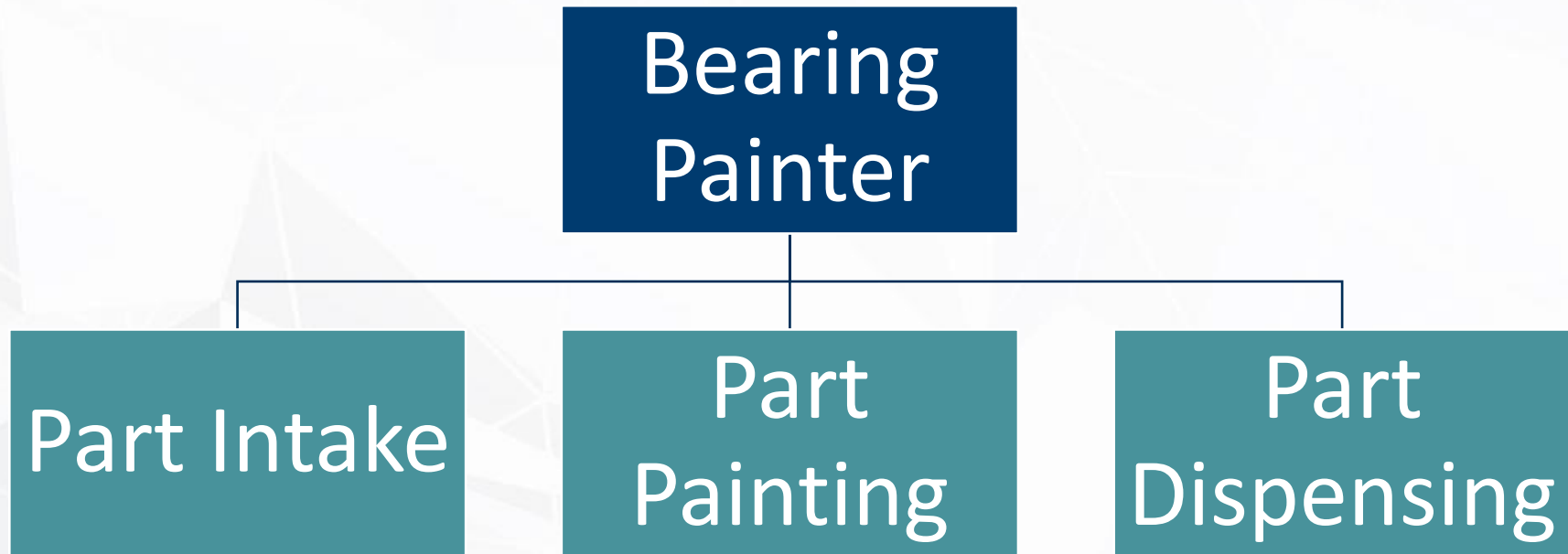

# Targets & Metrics

Andrew McClung



# Critical Targets

Consistently paint full 360° of retainers

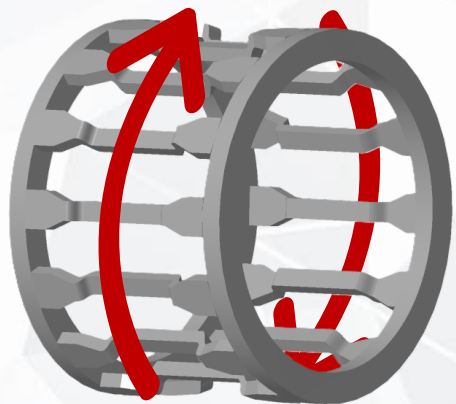

Cycle time of 3.5 seconds

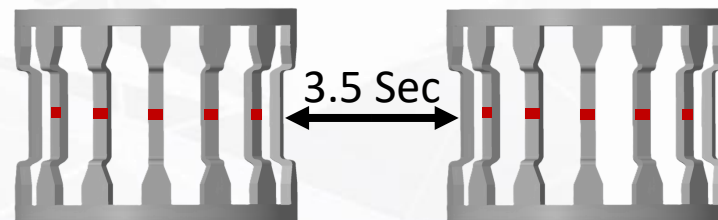

Fit inside a pre-existing Fume Hood (2ft. X 3ft. X 3ft.)



# Critical Targets

Limit Extraneous paint on working surface to 1 mm<sup>2</sup>

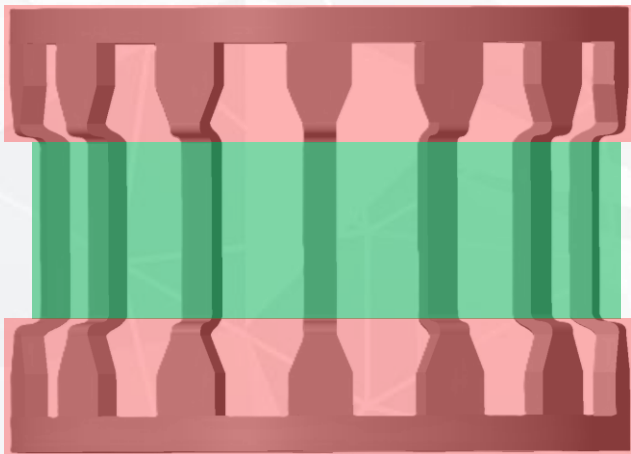

Accommodate retainers from 7/8 to 2 1/2 inches in diameter

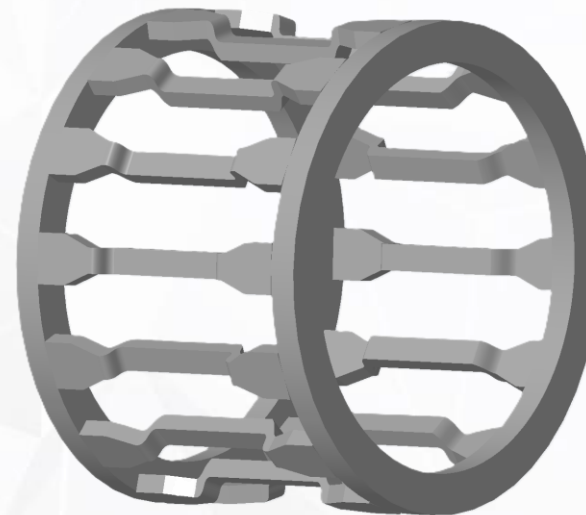



# Concept Generation

Mason Gibson



# Medium Fidelity Concept 1

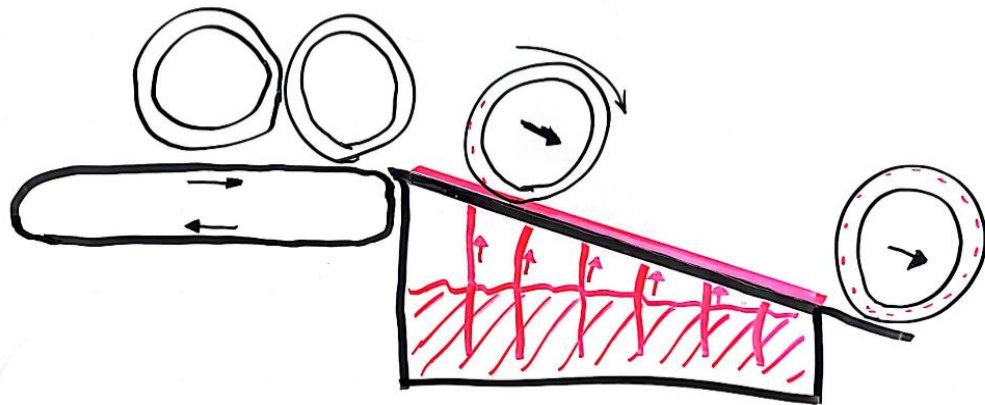

Concept 1

## Key Features

- Conveyor belt feeds the bearings
- Bearing rolls down a ramp to be painted
- Paint felt strip fed by a reservoir of Dykem underneath

# Medium Fidelity Concept 2

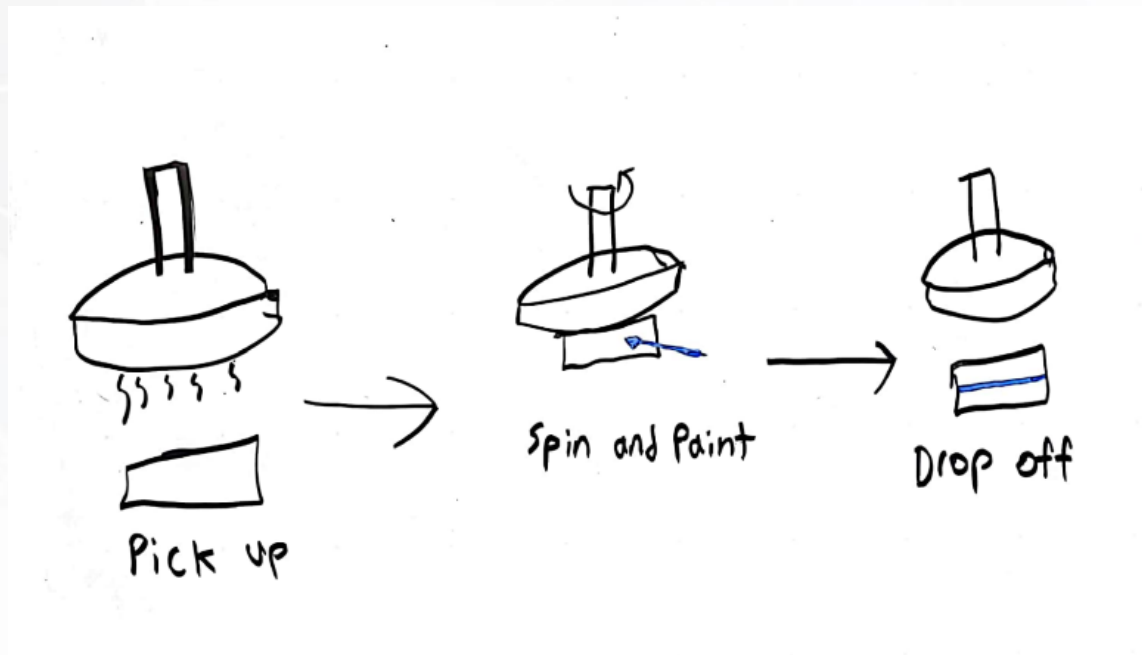

## Key Features

- Parts fed by a hopper mechanism
- An electromagnet is activated to pick up the bearings
- The magnet rotates to paint the bearing

# Medium Fidelity Concept 3



Cylinder with retractable spline

Bearing with spline attached

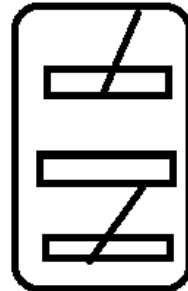

## Key Features

- Retractable spline
- Multiple bearings can be stacked down the spline
- The spline is manually loaded



# Medium Fidelity Concept 4

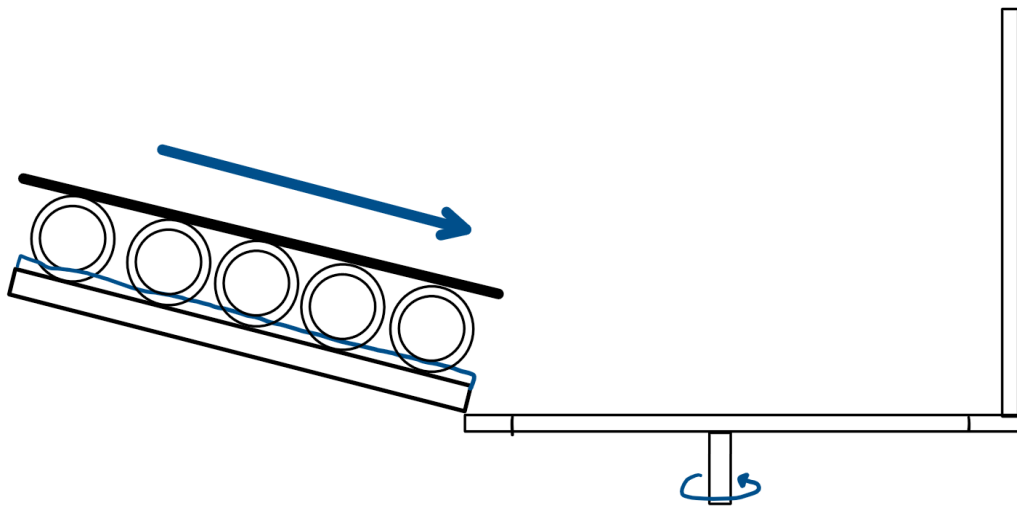

## Key Features

- Parts roll down an inclined track
- Rotating disk to assist with drying
- Would paint parts in batches instead of continuously

# Medium Fidelity Concept 5

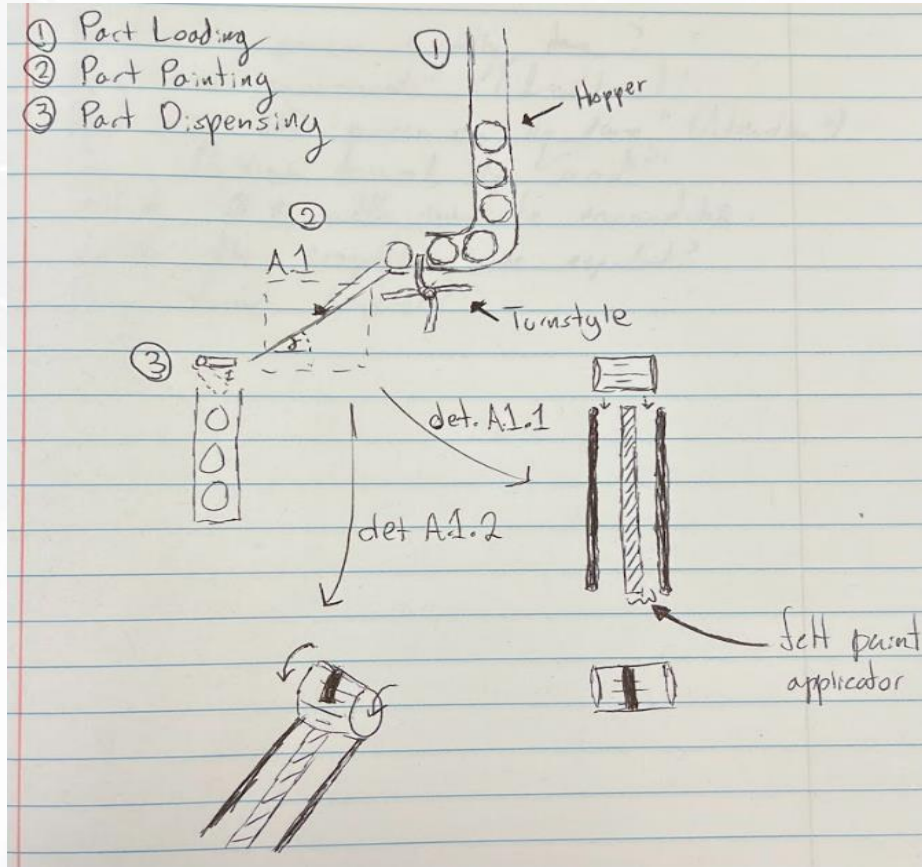

## Key Features

- Uses a vertical hopper that leads to a turnstile
- Inclined ramp that parts would roll down to get painted
- Finished bearings would stack at the base

# High Fidelity Concept 1 (Linear Processor)

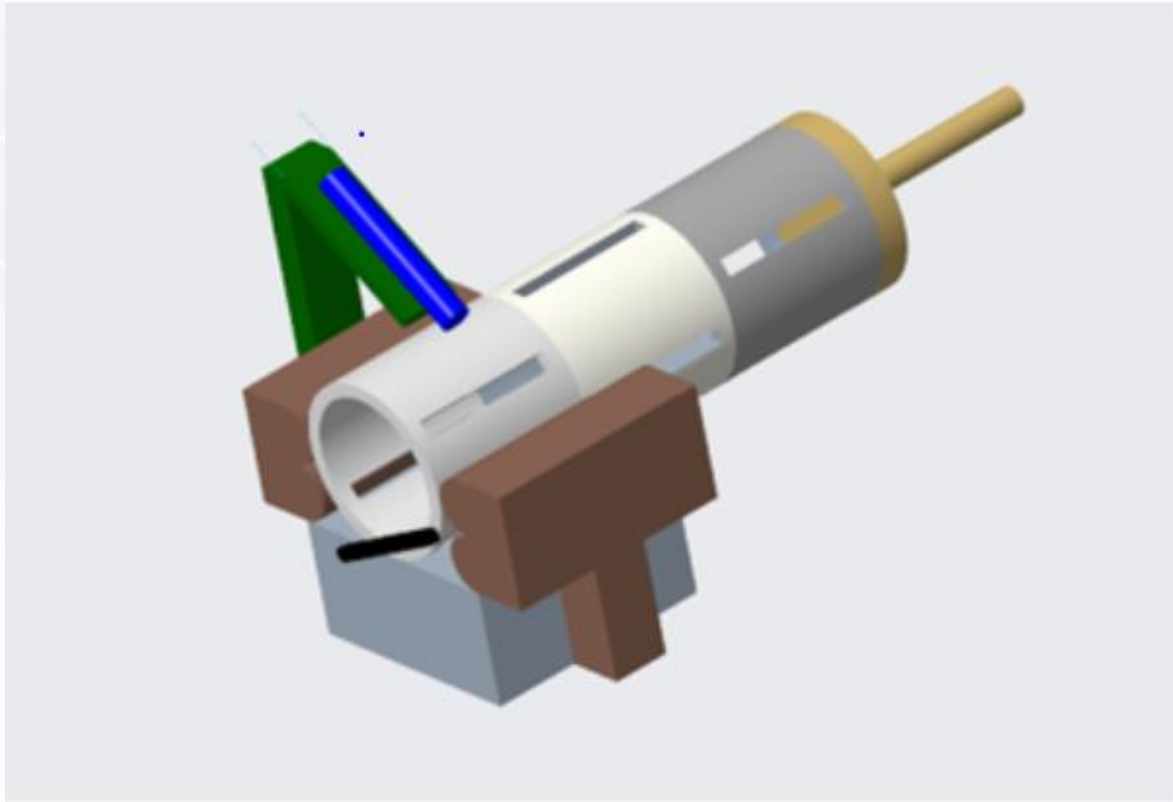

## Key Features

- Parts stack in line with a linear actuator
- Part at the end would be pushed on a belt and rotated
- Painting arm that pivots to paint the part

# High Fidelity Concept 2 (Inverted Treadmill)

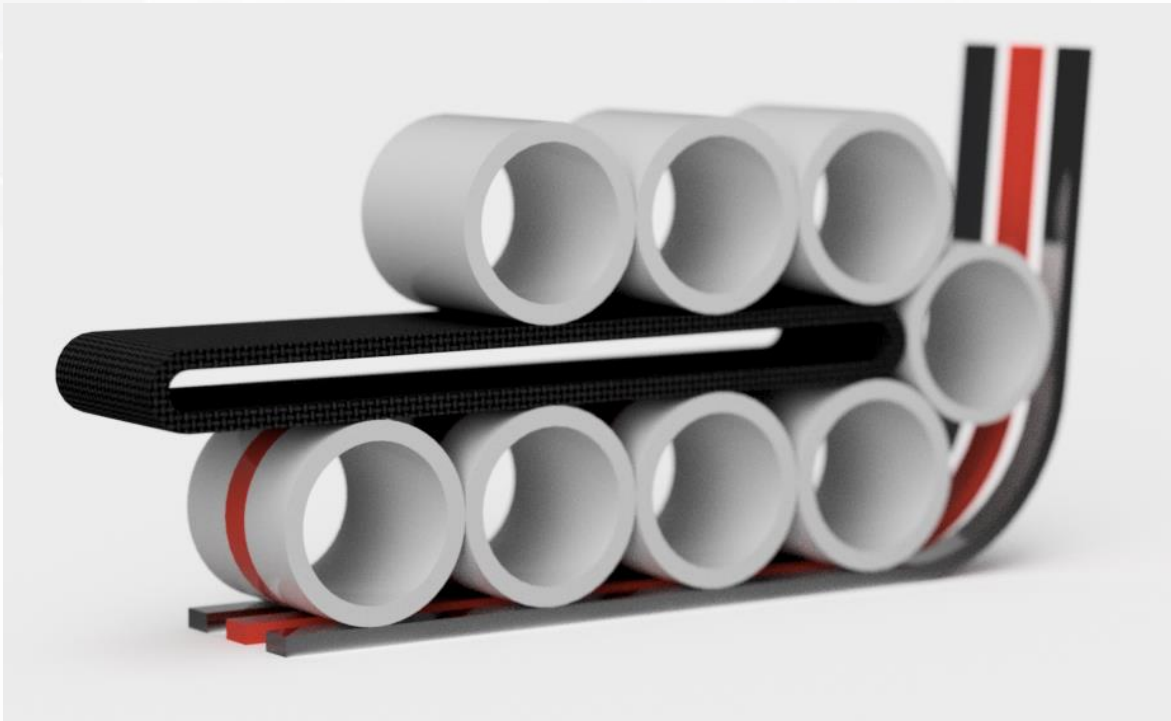

## Key Features

- Parts are moved along a belt to a surface with Dykem
- Pushed along the Dykem by the bottom of the belt
- Allows for compact design



# High Fidelity Concept 3 (Double Conveyor)

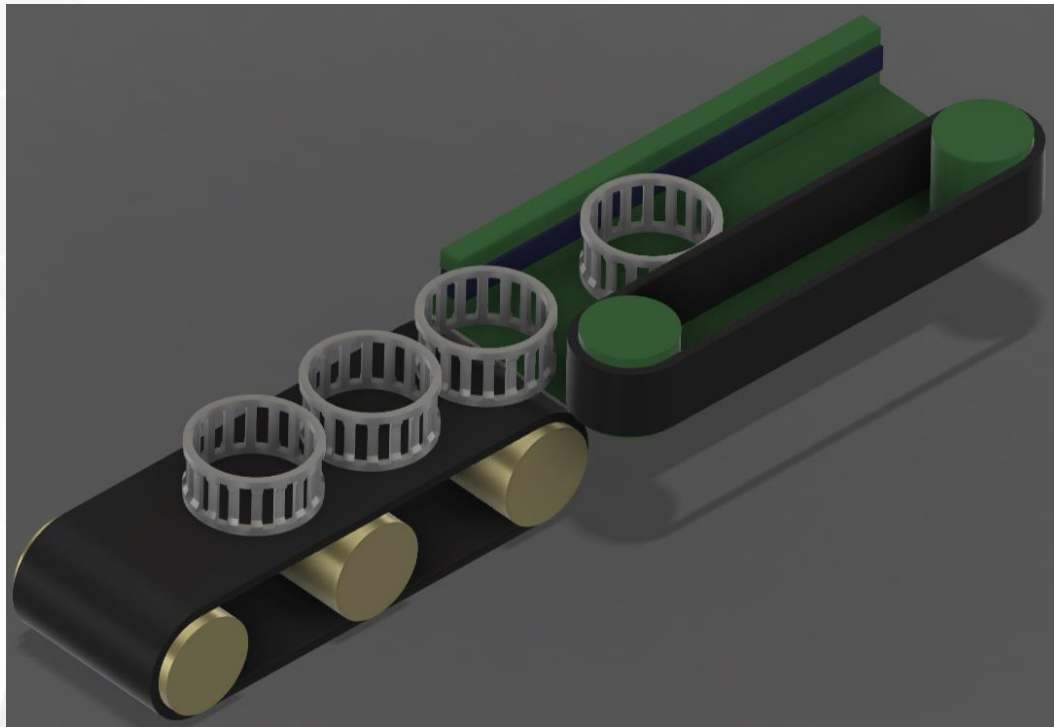

## Key Features

- Belt brings the parts into the painting system
- One belt moves the parts along while the other side paints
- Benchmarked from a labeling machine

# Concept Selection

Andrew McClung



# Selection Process

Binary Pairwise  
Comparison



House of  
Quality



Pugh Chart

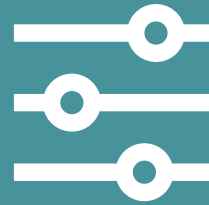

Analytical  
Hierarchy Process



# Binary Pairwise Comparison

## Function

- Tool to assist in ranking the importance of customer requirements
- Assigns each requirement an importance weight factor
- Requirements and weight factors assist in the development of the House of Quality



## Results

The 3 most important requirements were found to be:

1. Paint correct area
2. Process range of sizes
3. Use multiple colors



# House of Quality

Production Rate

Part Intake Limit

Processing Accuracy

Automatic Operation %

Compatibility

Reliability

Size

Maintenance Interval



# Pugh Chart

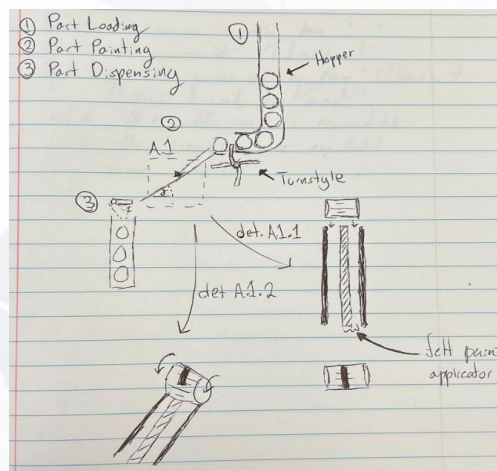
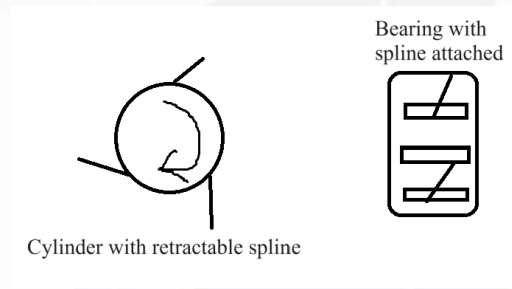
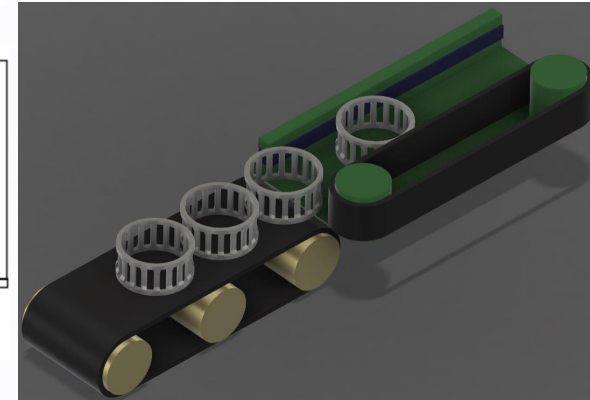
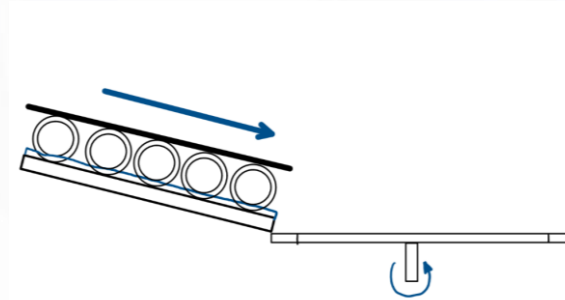
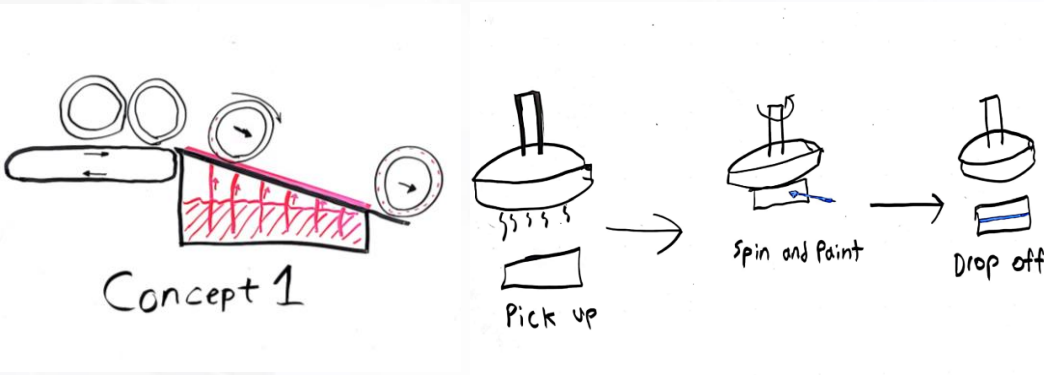

## DATUM

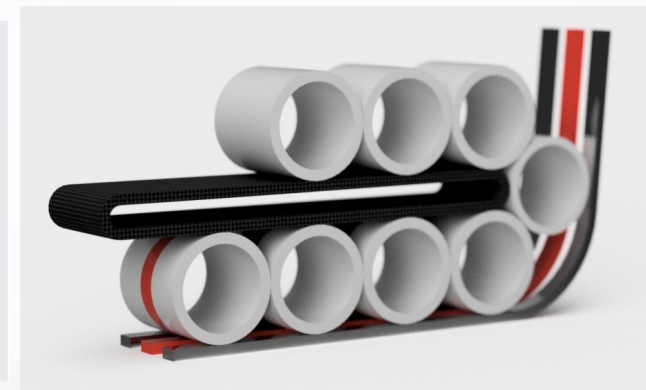
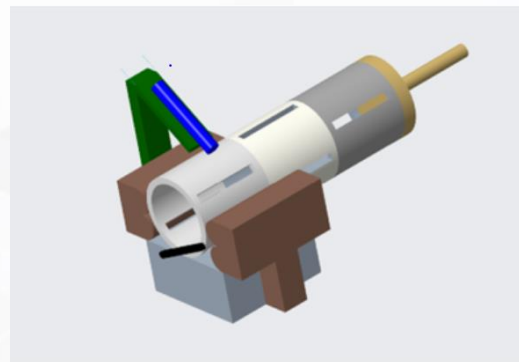

# Analytical Hierarchy Process

## Function

- Utilizes matrices to compare importance of criteria
- Criteria are Engineering characteristics & design concepts



## Results

- Compatibility is the highest weighted engineering characteristic
- Inverted Treadmill with the highest rating of importance on criteria

Concept	Alternative Value
Inverted Treadmill	0.401
Double Conveyor	0.271
Felt Ramp	0.327

# Final Selection

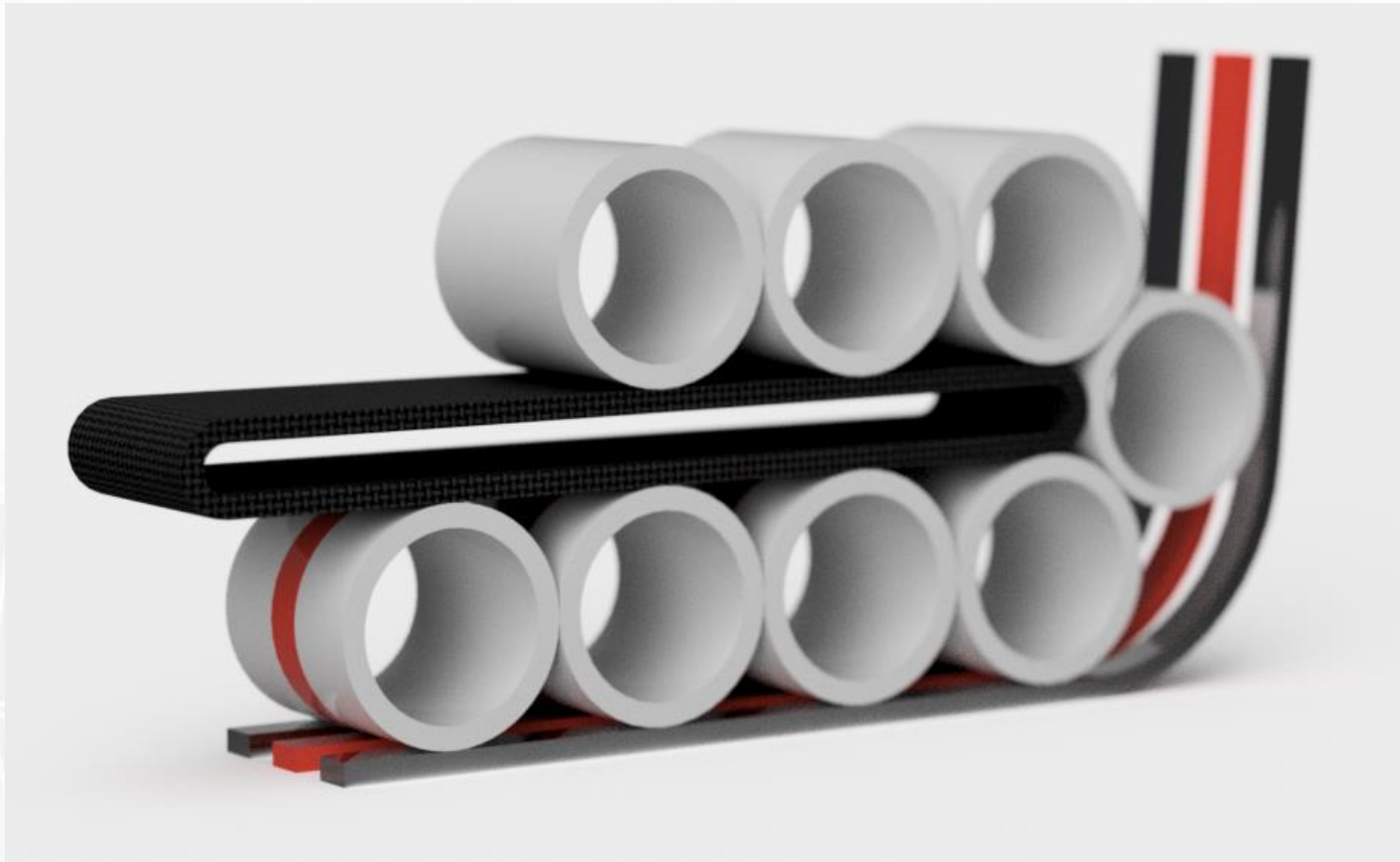

“Inverted Treadmill”

# Future Work

Testing with Dykem

Design Analysis

Developing CAD Models

Bill of Materials and Ordering



# Questions?



Team Introduction



Targets



Project Objective



Concept Generation



Project Overview



Selected Concept









# Retainer Painting

Some Customers Require Part Marking To Help Distinguish Similar Parts

- Low Production Runs
- Tedious, Manual Process
  - Operator Pulled From Position
  - Decreased Efficiency

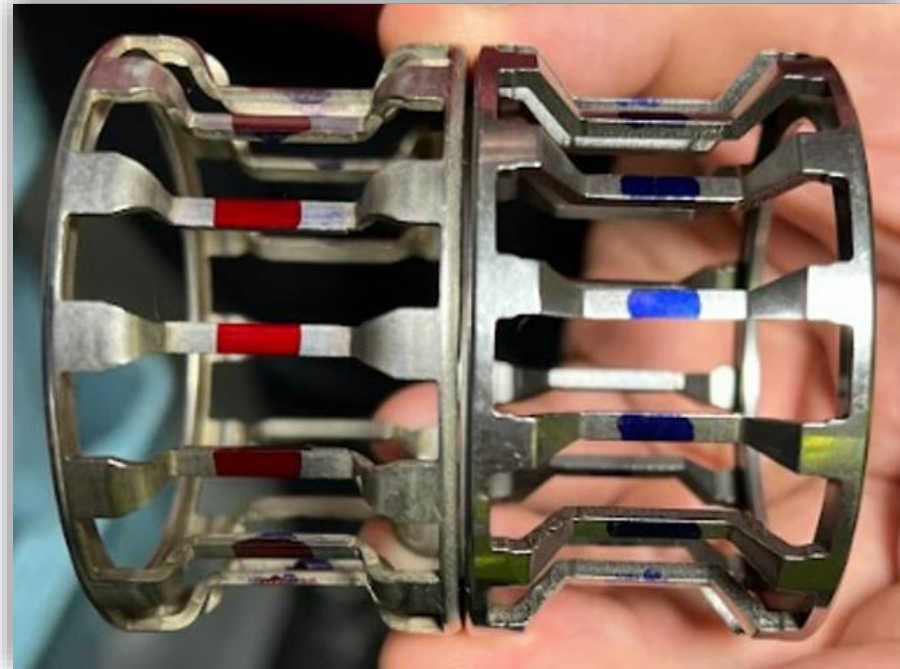

# Functions Hierarchy Chart

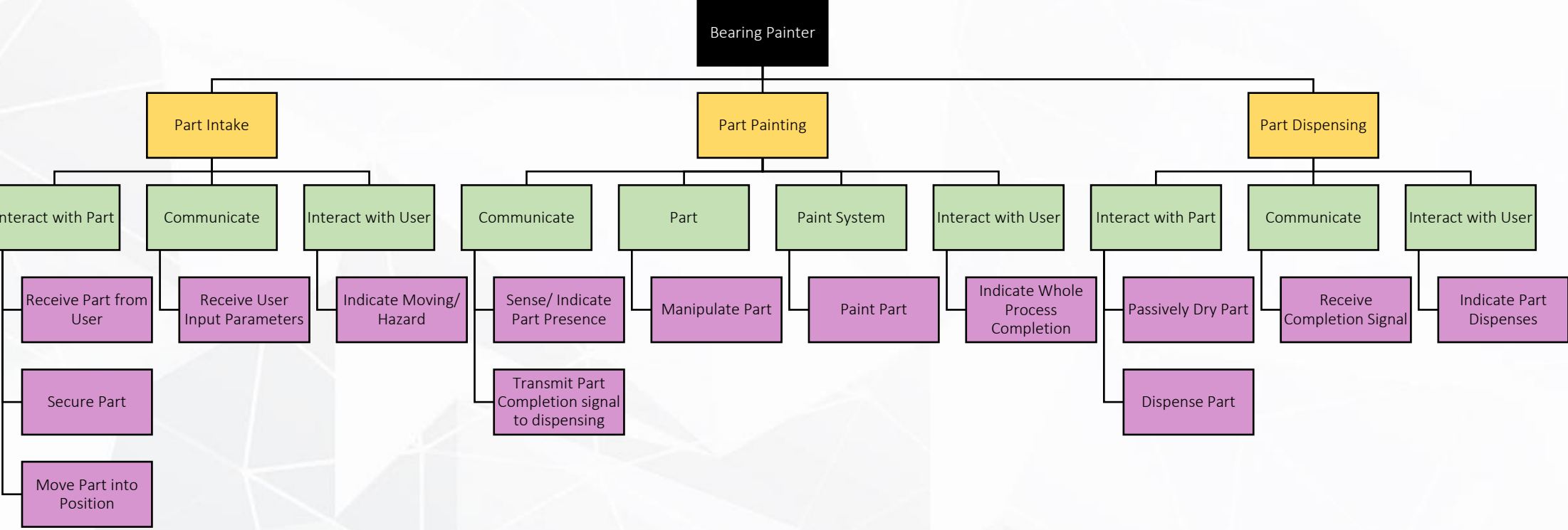

**Binary Pairwise Comparison Chart**

<b>Customer Requirements</b>	1	2	3	4	5	6	7	8	Total
1. Atomated Process	-	1	0	0	0	1	0	1	3
2. Cycle Time	0	-	1	0	0	1	0	1	3
3. Paint Correct Area	1	0	-	1	1	1	1	1	6
4. Fit in Fume Hood	1	1	0	-	0	1	0	1	4
5. Process Range of Sizes	1	1	0	1	-	1	0	1	5
6. Quickly Configurable	0	0	0	0	0	-	0	1	1
7. Use Multiple Colors	1	1	0	1	1	1	-	0	5
8. Indicate Operation Status	0	0	0	0	0	0	1	-	1
<b>Total</b>	4	4	1	3	2	6	2	6	$n - 1 = 7$



Engineering Characteristic									
Improvement Direction		↑	-	↑	↓	↑	↓	↓	-
Units		Part/min	mm <sup>2</sup>	Diameter	Sqft	Part/Load	%	%	Part/invl
Customer Requirements	Importance Weight Factor	Production Rate	Processing Accuracy	Compatibility	Size	Part Intake Limit	Automatic Operation %	Reliability	Maintenance Interval
1. Atomated Process	3	9		3	9	9	9		
2. Cycle Time	3	3	9	9		9	9	3	3
3. Paint Correct Area	6	1	9	9				1	1
4. Fit in Fume Hood	4			3	9	9			
5. Process Range of Sizes	5	1	9	9	9	3	9		
6. Quickly Configurable	1	3	3	9	3	9	3		
7. Use Multiple Colors	5	3	3		9	3	3	1	3
8. Indicate Operation Status	1	3		1		3	3	3	1
<b>Raw Score (628)</b>		68	144	157	156	132	120	23	31
<b>Relative Weight %</b>		10.83	22.93	25.00	24.84	21.02	19.11	3.66	4.94
<b>Rank Order</b>		6	3	1	2	4	5	8	7





Concepts									
Engineering Characteristics	RANDBRIG HT RB 60	Linear Processor	Inverted Treadmill	Double Conveyor	Felt Ramp	Electromagnet	Spline	Pore Track	Gravity Ramp
Compatibility	- DATUM -	S	S	-	S	-	S	+	+
Size		S	+	S	+	S	S	-	-
Part Intake Limit		S	+	S	S	S	S	S	S
Processing Accuracy		S	S	S	-	-	S	S	-
Automatic Operation %		S	+	+	S	+	S	S	-
<b>Total Pluses</b>		0	3	1	1	1	0	1	1
<b>Total Satisfactory</b>		5	2	3	3	2	5	3	1
<b>Total Minuses</b>		0	0	1	1	2	0	1	3

Concepts					
Engineering Characteristics	Linear Processor	Inverted Treadmill	Double Conveyor	Felt Ramp	Pore Track
Compatibility	- DATUM -	S	S	+	-
Size		+	S	-	-
Part Intake Limit		+	+	S	S
Processing Accuracy		+	+	-	-
Automatic Operation %		+	+	S	S
<b>Total Pluses</b>		4	3	1	0
<b>Total Satisfactory</b>		1	2	2	2
<b>Total Minuses</b>		0	0	2	3



[C] Matrix

[C] Matrix							
	Analytical Hierarchy Process	A	A	A	A	A	
B	Engineering Characteristic	Compatibility	Size	Part Intake Limit	Processing Accuracy	Automatic Operation %	Average
B	Compatibility	1	3.000	3.000	7.000	5.000	3.800
B	Size	0.333	1	0.333	5.000	0.333	1.400
B	Part Intake Limit	0.333	3.000	1	7.000	1.000	2.467
B	Processing Accuracy	0.143	0.200	0.143	1	0.200	0.337
B	Automatic Operation %	0.200	3.000	1.000	5.000	1	2.040
	<b>Total</b>	2.010	10.200	5.476	25.000	7.533	10.044
	<b>Average</b>	0.402	2.040	1.095	5.000	1.507	

Concept	Alternative Value
Inverted Treadmill	0.401
Double Conveyor	0.271
Felt Ramp	0.327

# Backup Slides





- This is 10-point
- This is 15-point Times
- This is 20-point
- This is 25-point
- This is 30-point
- This is 35-point
- This is 40-point
- This is 50-point
- This is 60-point

